

HANGERS

HANGER, SQUARE DUCT

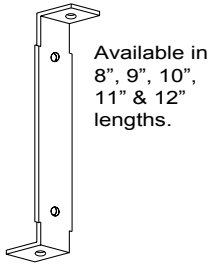

Available in 8", 9", 10", 11" & 12" lengths.

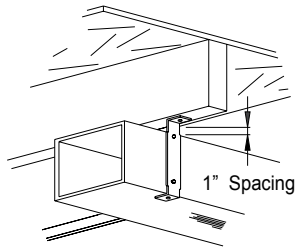

8" to 12" Hanger for standard or larger supply and return runs.
Used on both Hot Air Supply and Cold Air Return ducts.

PART NUMBER:	BH-8	BH-9	BH-10	BH-11	BH-12
LENGTH:	8"	9"	10"	11"	12"
MATERIAL:	Galv. Steel	Galv. Steel	Galv. Steel	Galv. Steel	Galv. Steel
GAUGE:	18	18	18	18	18
QUANTITY PER CARTON:	100	100	100	100	100
WT. PER CARTON (Lbs.)	10	12	14	15	16

HANGER, ROUND DUCT



Self Nailing

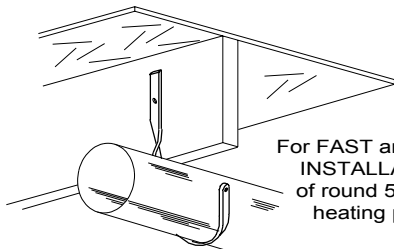

For FAST and EASY INSTALLATION of round 5" or 6" heating pipes

PART NUMBER:	BH-2
DIAMETER:	5" or 6"
MATERIAL:	Galv. Steel
GAUGE:	18
QUANTITY PER CARTON:	50
WT. PER CARTON (Lbs.)	5

HANGER, WIRE DUCT STRAP

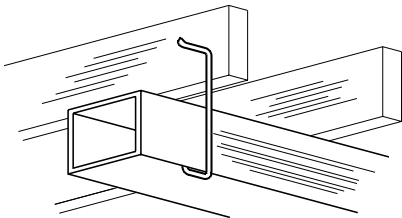

Used for suspending square duct without the use of nails, rivets or screws.

PART NUMBER:	GWS-49	GWS-412
LENGTH:	9"	12"
MATERIAL:	Galv. Steel	Galv. Steel
GAUGE:	9	9
QUANTITY PER CARTON:	100	100
WT. PER CARTON (Lbs.)	6	8

HANGER, DUCT STRAP

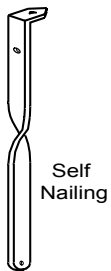

Self Nailing

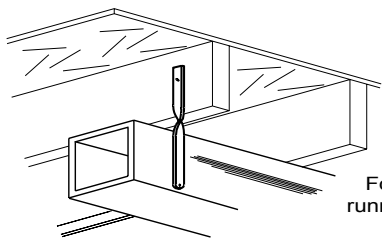

For all square ducts running below the joists

PART NUMBER:	DS-3
MATERIAL:	Galv. Steel
GAUGE:	18
QUANTITY PER CARTON:	100
WT. PER CARTON (Lbs.)	5

HANGER, FLEX-DUCT SADDLE

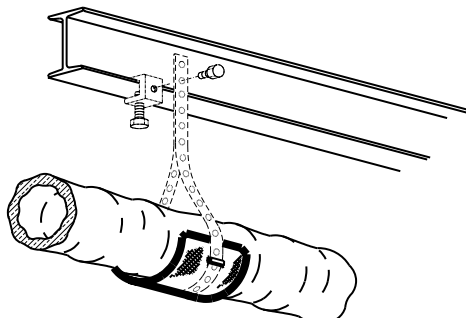
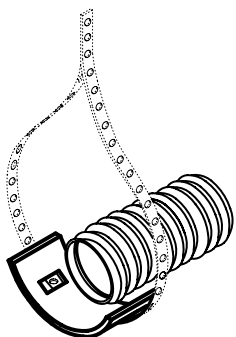

For use in supporting flexible duct work where a metal support is preferred or required over plastic or mesh.

Designed to be used with Basset 3/4" wide strapping. Strapping not included. (See page 200-04)

PART NUMBER:	FDS-9	FDS-12
SIZE:	9" x 4"	12" x 4"
MATERIAL:	Galv. Steel	Galv. Steel
GAUGE:	30	30
QUANTITY PER CARTON:	25	25
WT. PER CARTON (Lbs.)	4	6